

Torque Motor

TMRW Series



- Frameless
- Water cooling
- Large hollow shaft



TMRWax

Specifications

	Symbol	Unit	TMRWA3	TMRWA3L	TMRWA5	TMRWA5L	TMRWA7	TMRWA7L	TMRWAA	TMRWAAL	TMRWAF	TMRWAF L
Continuous torque (Free air convection)	T_c	Nm	117	117	195	195	274	274	390	390	585	585
Continuous current (Free air convection)	I_c	A_{rms}	6	12	6	12	12	18	12	18	18	24
Continuous torque (WC)	T_c	Nm	260	260	430	430	600	600	860	860	1290	1290
Continuous current (WC)	I_c	A_{rms}	15	30	15	30	30	45	30	45	45	60
Peak torque(for 1sec.)	T_p	Nm	490	490	810	810	1100	1100	1600	1600	2400	2400
Peak current(for 1sec.)	I_p	A_{rms}	40.5	81	40.5	81	81	121.5	81	121.5	121.5	162
Torque constant	K_t	Nm/A_{rms}	19.57	9.79	32.6	16.32	22.84	15.23	32.63	21.75	32.63	24.45
Electrical time constant	T_e	ms	10	10	10	10	10	10	10	10	10	10
Resistance (line to line at 25°C)	R_{25}	Ω	3.57	0.89	5.95	1.48	2.08	0.92	2.97	1.32	1.98	1.11
Inductance (line to line)	L	mH	35.7	8.93	59.5	14.88	20.84	9.26	29.76	13.23	19.85	11.11
Number of poles	2p		66	66	66	66	66	66	66	66	66	66
Back emf constant (line to line)	K_v	$V_{rms}/rad/s$	11.3	5.65	18.8	9.42	13.18	8.79	18.83	12.55	18.83	14.12
Motor constant (at 25°C)	K_m	N/\sqrt{W}	8.46	8.47	10.91	10.95	12.93	12.96	15.46	15.46	18.93	18.95
Thermal resistance (Free air convection)	R_{th}	$^{\circ}C/W$	0.49	0.49	0.3	0.3	0.21	0.21	0.15	0.15	0.1	0.1
Thermal resistance (WC)	R_{th}	$^{\circ}C/W$	0.079	0.079	0.047	0.048	0.034	0.034	0.024	0.024	0.016	0.016
Thermal sensor			PTC SNM100+SNM120+KTY84									
Max. DC BUS	V_{DC}		600									
Inertia of rotor	J	kgm^2	0.065	0.065	0.1	0.1	0.15	0.15	0.21	0.21	0.32	0.32
Max. speed at conti. Torque (AC)		rpm	250	510	140	300	210	320	140	220	140	200
Max. speed at conti. Torque (WC)		rpm	160	340	90	200	135	210	90	140	92	125
Max. speed at max. Torque		rpm	65	150	35	80	55	90	35	60	35	50
Mass of rotor		kg	3.1	3.1	5.1	5.1	7.1	7.1	10.2	10.2	15.3	15.3
Mass of stator		kg	20.1	20.1	26.8	26.8	34.5	34.5	44.9	44.9	63.1	63.1
Height of stator	H_s	mm	90	90	110	110	130	130	160	160	210	210
Height of rotor	H_r	mm	31	31	51	51	71	71	101	101	151	151
Length	H	mm	10	10	15	15	15	15	15	15	15	15

WC: with water cooling

Except dimensions, all the specifications in the table are in $\pm 10\%$ of tolerance.

Note: The specification is estimative value. The value will be modified and correct after measuring motors.

Dimensions

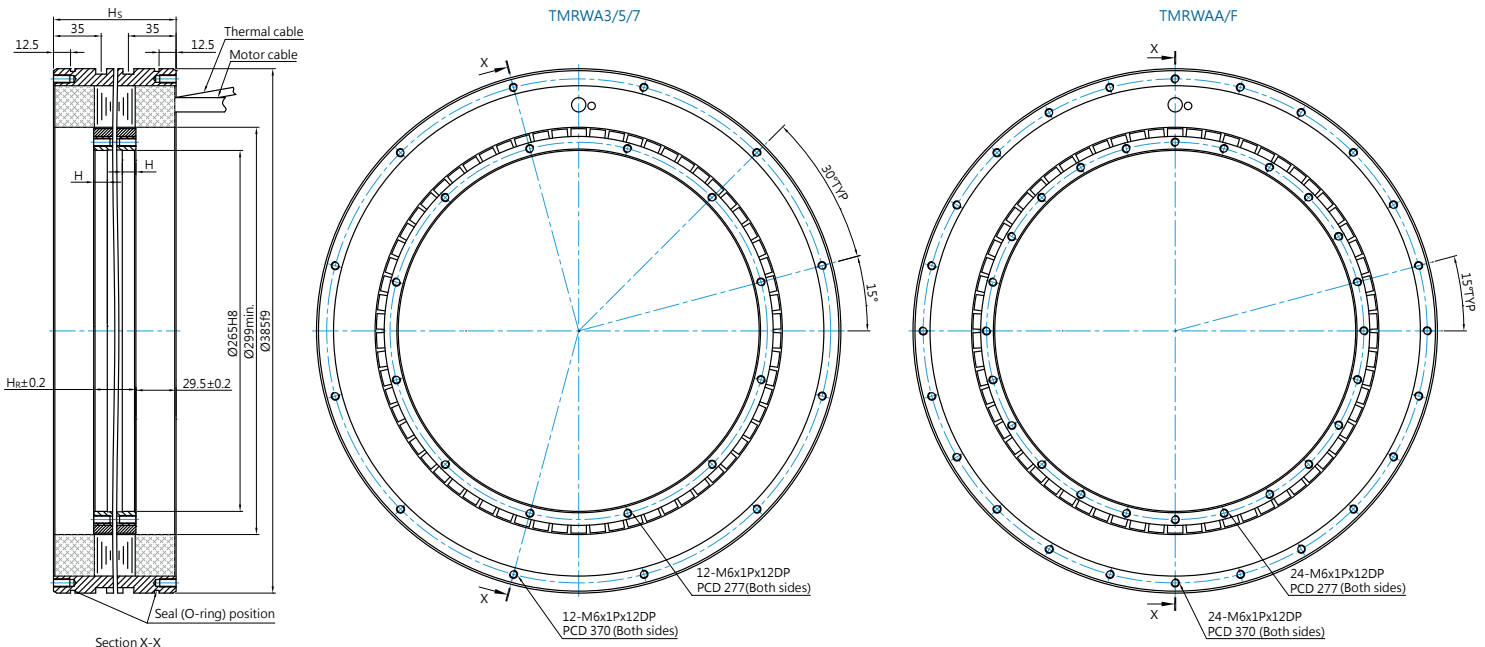

TMRWDx

Specifications

	Symbol	Unit	TMRWD3	TMRWD3L	TMRWD5	TMRWD5L	TMRWD7	TMRWD7L	TMRWDA	TMRWDAL	TMRWDF	TMRWDFL
Continuous torque (Free air convection)	T_c	Nm	185	185	310	310	430	430	619	619	925	925
Continuous current (Free air convection)	I_c	A_{rms}	12	24	12	24	12	24	12	24	24	48
Continuous torque (WC)	T_c	Nm	400	400	660	660	930	930	1340	1340	2000	2000
Continuous current (WC)	I_c	A_{rms}	30	60	30	60	30	60	30	60	60	120
Peak torque(for 1sec.)	T_p	Nm	750	750	1230	1230	1760	1760	2470	2470	3600	3600
Peak current(for 1sec.)	I_p	A_{rms}	81	162	81	162	81	162	81	162	162	324
Torque constant	K_t	Nm/A_{rms}	15.48	7.74	25.8	12.9	36.11	18.1	51.6	25.8	38.7	19.35
Electrical time constant	T_e	ms	7	7	7	8	7	7	7	7	7	7
Resistance (line to line at 25°C)	R_{25}	Ω	1.57	0.39	2.31	0.59	3.04	0.76	4.14	1.04	1.59	0.37
Inductance (line to line)	L	mH	11.13	2.78	16.3	4.78	21.5	5.38	29.3	7.33	10.57	2.64
Number of poles	2p		88	88	88	88	88	88	88	88	88	88
Back emf constant (line to line)	K_v	$V_{rms}/rad/s$	8.94	4.47	14.9	7.45	20.85	10.43	29.8	14.9	22.35	11.18
Motor constant (at 25°C)	K_m	N/\sqrt{W}	10.05	10.04	13.88	13.68	16.78	16.78	20.70	20.70	24.96	25.76
Thermal resistance (Free air convection)	R_{th}	$^{\circ}C/W$	0.28	0.28	0.19	0.19	0.14	0.14	0.11	0.11	0.07	0.07
Thermal resistance (WC)	R_{th}	$^{\circ}C/W$	0.045	0.045	0.030	0.030	0.023	0.023	0.017	0.017	0.011	0.012
Thermal sensor			PTC SNM100+SNM120+KTY84									
Max. DC BUS	V_{DC}		600									
Inertia of rotor	J	kgm^2	0.16	0.16	0.26	0.26	0.37	0.37	0.53	0.53	0.8	0.8
Max. speed at conti. Torque (AC)		rpm	300	630	180	390	130	275	90	19	125	260
Max. speed at conti. Torque (WC)		rpm	200	420	120	250	85	190	60	133	80	190
Max. speed at max. Torque		rpm	85	175	50	115	30	85	18	60	30	80
Mass of rotor		kg	5.5	5.5	9.2	9.2	12.8	12.8	18.3	18.3	27.4	27.4
Mass of stator		kg	22.8	22.8	38	38	53.2	53.2	76	76	114	114
Height of stator	H_s	mm	90	90	110	110	130	130	160	160	210	210
Height of rotor	H_R	mm	31	31	51	51	71	71	101	101	151	151
Length	H	mm	10	10	15	15	15	15	15	15	15	15

WC: with water cooling

Except dimensions, all the specifications in the table are in $\pm 10\%$ of tolerance.

Note: The specification is estimative value. The value will be modified and correct after measuring motors.

Dimensions

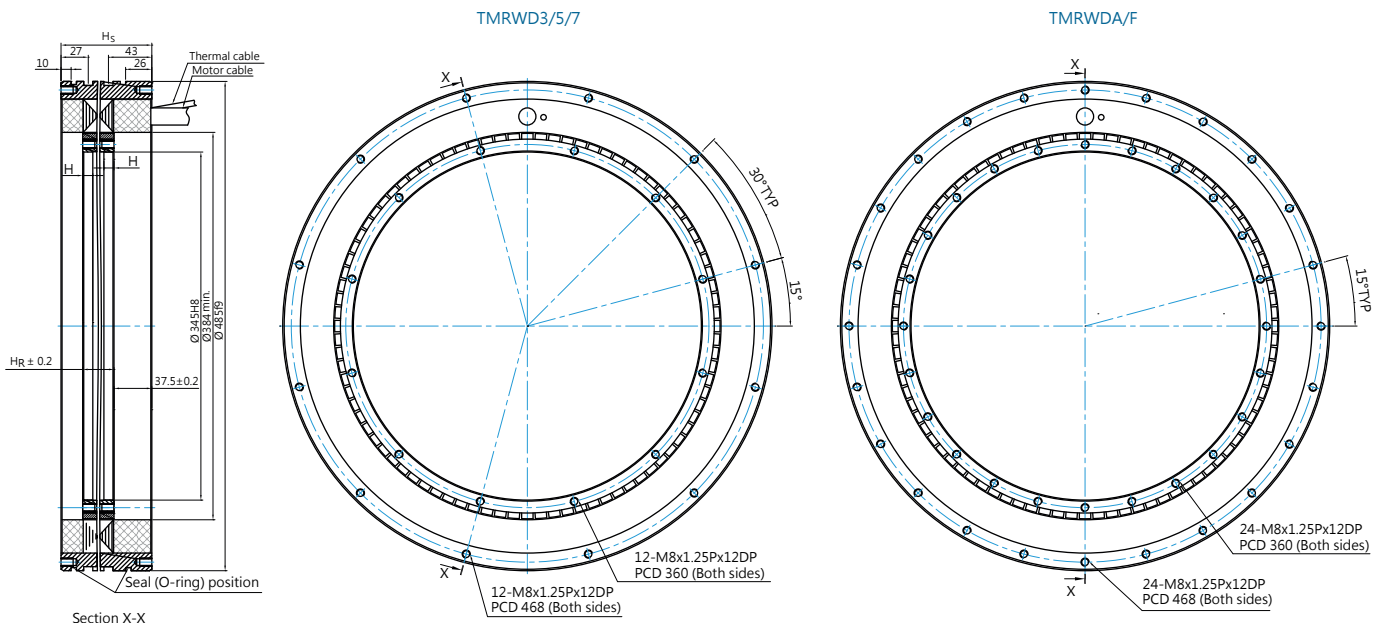

TMRW1x

Specifications

	Symbol	Unit	TMRW13	TMRW13L	TMRW15	TMRW15L	TMRW17	TMRW17L	TMRW1A	TMRW1AL	TMRW1F	TMRW1FL
Continuous torque (Free air convection)	T_c	Nm	7.5	7.5	12.4	12.4	17.4	17.4	24.9	24.9	37.3	37.3
Continuous current (Free air convection)	I_c	A_{rms}	4	5.7	4	5.7	4	5.7	4	5.7	5.7	11.4
Continuous torque (WC)	T_c	Nm	18.8	18.8	31.3	31.3	43.8	43.8	62.5	62.5	93.8	93.8
Continuous current (WC)	I_c	A_{rms}	10	14.4	10	14.4	10	14.4	10	14.4	14.4	28.8
Peak torque(for 1sec.)	T_p	Nm	35.6	35.6	59.4	59.4	83.1	83.1	118.8	118.8	178.1	178.1
Peak current(for 1sec.)	I_p	A_{rms}	27	38.9	27	38.9	27	38.9	27	38.9	38.9	77.8
Torque constant	K_t	Nm/A_{rms}	1.87	1.32	3.1	2.18	4.36	3.06	6.23	4.36	6.55	3.27
Electrical time constant	T_e	ms	3.6	3.6	3.6	3.6	3.6	3.6	3.6	3.6	3.6	3.6
Resistance (line to line at 25°C)	R_{25}	Ω	2.92	1.42	4.88	2.36	6.83	3.32	9.75	4.74	7.11	1.78
Inductance (line to line)	L	mH	10.5	5.1	17.5	9	24.5	11.9	35	17.01	25.52	6.38
Number of poles	2p		22	22	22	22	22	22	22	22	22	22
Back emf constant (line to line)	K_v	$V_{rms}/rad/s$	1.08	0.76	1.8	1.26	2.52	1.76	3.6	2.52	3.78	1.89
Motor constant (at 25°C)	K_m	N/\sqrt{W}	0.89	0.9	1.15	1.16	1.36	1.37	1.63	1.64	2.01	2
Thermal resistance (Free air convection)	R_{th}	$^{\circ}C/W$	1.36	1.37	0.81	0.83	0.58	0.59	0.41	0.41	0.27	0.27
Thermal resistance (WC)	R_{th}	$^{\circ}C/W$	0.217	0.215	0.13	0.129	0.093	0.092	0.065	0.064	0.043	0.043
Thermal sensor			PTC SNM100+SNM120+KTY84									
Max. DC BUS	V_{DC}		600									
Inertia of rotor	J	kgm^2	0.001	0.001	0.0016	0.0016	0.0023	0.0023	0.0033	0.0033	0.0049	0.0049
Max. speed at conti. Torque (AC)		rpm	2800	4000	1600	2400	1150	1700	800	1170	760	1600
Max. speed at conti. Torque (WC)		rpm	2200	3200	1200	1750	830	1590	600	870	540	1200
Max. speed at max. Torque		rpm	1000	1600	600	830	400	610	580	390	210	560
Mass of rotor		kg	0.6	0.6	1	1	1.4	1.4	2	2	3	3
Mass of stator		kg	3.7	3.7	5.1	5.1	6.2	6.2	8.6	8.6	12.2	12.2
Height of stator	H_s	mm	70	70	90	90	110	110	140	140	190	190
Height of rotor	H_r	mm	31	31	51	51	71	71	101	101	151	151
Length	H	mm	10	10	15	15	15	15	15	15	15	15

WC: with water cooling

Except dimensions, all the specifications in the table are in $\pm 10\%$ of tolerance.

Note: The specification is estimative value. The value will be modified and correct after measuring motors.

Dimensions

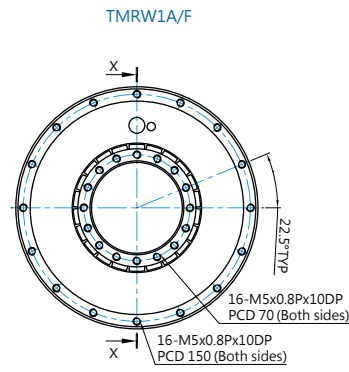
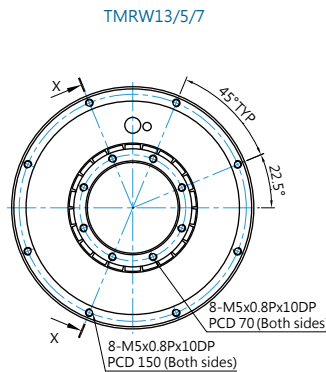
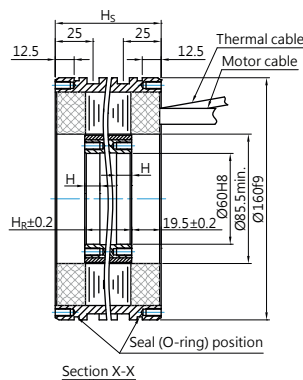

TMRW2x

Specifications

	Symbol	Unit	TMRW23	TMRW23L	TMRW25	TMRW25L	TMRW27	TMRW27L	TMRW2A	TMRW2AL	TMRW2F	TMRW2FL
Continuous torque (Free air convection)	T_c	Nm	14.2	14.2	23.6	23.6	33	33	47.3	47.3	71	71
Continuous current (Free air convection)	I_c	A_{rms}	3.3	4.9	3.3	4.9	3.3	4.9	3.3	4.9	4.9	9.9
Continuous torque (WC)	T_c	Nm	35	35	59	59	82.5	82.5	117.5	117.5	176	176
Continuous current (WC)	I_c	A_{rms}	8.3	12.3	8.3	12.3	8.3	12.3	8.3	12.3	12.3	24.6
Peak torque(for 1sec.)	T_p	Nm	66.5	66.5	112	112	156	156	223	223	334.5	334.5
Peak current(for 1sec.)	I_p	A_{rms}	22.3	33.2	22.3	33.2	22.3	33.2	22.3	33.2	33.2	66.4
Torque constant	K_t	Nm/A_{rms}	4.29	2.88	7.16	4.8	10.03	6.72	14.32	9.6	14.39	7.2
Electrical time constant	T_e	ms	6.5	6.5	6.5	6.5	6.5	6.5	6.5	6.5	6.5	6.5
Resistance (line to line at 25°C)	R_{25}	Ω	3.34	1.5	5.57	2.5	7.8	3.5	11.14	5	7.49	1.87
Inductance (line to line)	L	mH	21.73	9.74	36.21	16.23	50.7	22.72	72.43	32.46	48.69	12.17
Number of poles	2p		22	22	22	22	22	22	22	22	22	22
Back emf constant (line to line)	K_v	$V_{rms}/rad/s$	2.48	1.66	4.13	2.77	5.79	3.88	8.27	5.54	8.31	4.15
Motor constant (at 25°C)	K_m	N/\sqrt{W}	1.92	1.92	2.48	2.48	2.93	2.93	3.5	3.51	4.29	4.3
Thermal resistance (Free air convection)	R_{th}	$^{\circ}C/W$	1.74	1.74	1.04	1.04	0.75	0.74	0.52	0.52	0.35	0.35
Thermal resistance (WC)	R_{th}	$^{\circ}C/W$	0.279	0.279	0.167	0.167	0.119	0.12	0.084	0.084	0.056	0.056
Thermal sensor			PTC SNM100+SNM120+KTY84									
Max. DC BUS	V_{DC}		600									
Inertia of rotor	J	kgm^2	0.0027	0.0027	0.0045	0.0045	0.0063	0.0063	0.009	0.009	0.013	0.013
Max. speed at conti. Torque (AC)		rpm	1260	1900	750	1130	525	800	360	550	360	740
Max. speed at conti. Torque (WC)		rpm	1060	1600	610	950	420	660	280	440	275	610
Max. speed at max. Torque		rpm	590	900	330	525	210	360	125	225	120	330
Mass of rotor		kg	0.95	0.95	1.6	1.6	2.2	2.2	3.2	3.2	4.8	4.8
Mass of stator		kg	6.1	6.1	8.4	8.4	10.2	10.2	14.2	14.2	20.1	20.1
Height of stator	H_s	mm	80	80	100	100	120	120	150	150	200	200
Height of rotor	H_R	mm	31	31	51	51	71	71	101	101	151	151
Length	H	mm	10	10	15	15	15	15	15	15	15	15

WC: with water cooling

Except dimensions, all the specifications in the table are in $\pm 10\%$ of tolerance.

Note: The specification is estimative value. The value will be modified and correct after measuring motors.

Dimensions

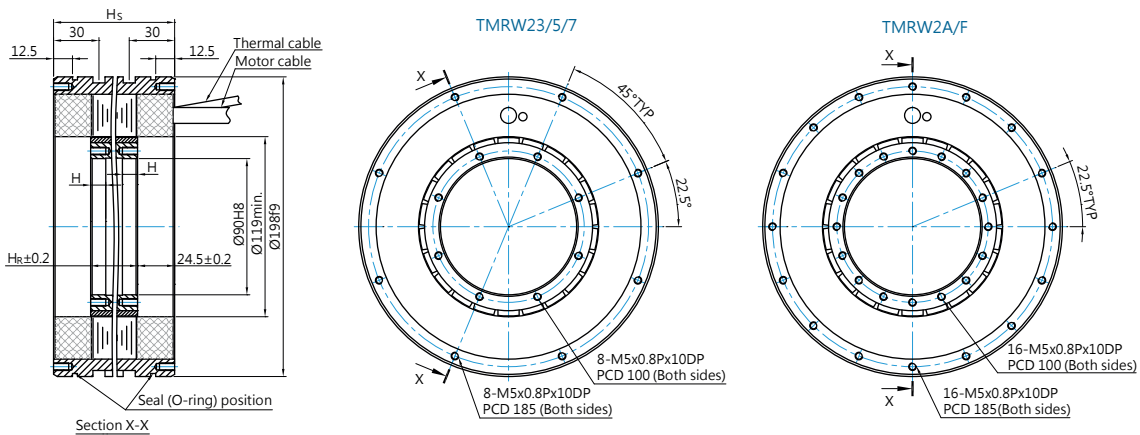

TMRW4x

Specifications

	Symbol	Unit	TMRW43	TMRW43L	TMRW45	TMRW45L	TMRW47	TMRW47L	TMRW4A	TMRW4AL	TMRW4F	TMRW4FL
Continuous torque (Free air convection)	T_c	Nm	28.2	28.2	47	47	65	65	91	91	136	136
Continuous current (Free air convection)	I_c	A_{rms}	4	8	4	8	4	8	8	12	8	12
Continuous torque (WC)	T_c	Nm	63.5	63.5	106	106	148	148	205	205	307	307
Continuous current (WC)	I_c	A_{rms}	9	18	9	18	9	18	18	27	18	27
Peak torque(for 1sec.)	T_p	Nm	120	120	203	203	280	280	390	390	583	583
Peak current(for 1sec.)	I_p	A_{rms}	24.3	48.6	24.3	48.6	24.3	48.6	48.6	72.9	48.6	72.9
Torque constant	K_t	Nm/A_{rms}	7.06	3.53	11.76	5.88	16.47	8.23	11.76	7.61	17.65	11.42
Electrical time constant	T_e	ms	5	5	5	5	5	5	5	5	5	5
Resistance (line to line at 25°C)	R_{25}	Ω	2.93	0.73	4.88	1.22	6.83	1.7	2.44	1.06	3.66	1.58
Inductance (line to line)	L	mH	15.3	3.83	25.5	6.38	35.7	8.93	12.75	5.52	19.13	8.28
Number of poles	2p		22	22	22	22	22	22	22	22	22	22
Back emf constant (line to line)	K_v	$V_{rms}/rad/s$	4.08	2.04	6.8	3.4	9.5	4.75	6.79	4.39	10.19	6.59
Motor constant (at 25°C)	K_m	N/\sqrt{W}	3.36	3.37	4.34	4.34	5.08	5.09	5.95	6.01	7.26	7.36
Thermal resistance (Free air convection)	R_{th}	$^{\circ}C/W$	1.35	1.36	0.81	0.81	0.58	0.58	0.41	0.41	0.27	0.28
Thermal resistance (WC)	R_{th}	$^{\circ}C/W$	0.267	0.268	0.160	0.160	0.114	0.115	0.080	0.082	0.053	0.055
Thermal sensor			PTC SNM100+SNM120+KTY84									
Max. DC BUS	V_{DC}		600									
Inertia of rotor	J	kgm^2	0.0085	0.0085	0.014	0.014	0.022	0.022	0.029	0.029	0.045	0.045
Max. speed at conti. Torque (AC)		rpm	790	1600	460	950	320	670	460	730	300	470
Max. speed at conti. Torque (WC)		rpm	730	1500	420	890	290	620	420	680	260	440
Max. speed at max. Torque		rpm	540	1100	290	660	180	450	300	500	160	300
Mass of rotor		kg	1.4	1.4	2.4	2.4	3.3	3.3	4.7	4.7	7.1	7.1
Mass of stator		kg	5.8	5.8	7.8	7.8	9.6	9.6	12.7	12.7	18.7	18.7
Height of stator	H_s	mm	70	70	90	90	110	110	140	140	190	190
Height of rotor	H_r	mm	31	31	51	51	71	71	101	101	151	151
Length	H	mm	10	10	15	15	15	15	15	15	15	15

WC: with water cooling

Except dimensions, all the specifications in the table are in $\pm 10\%$ of tolerance.

Note: The specification is estimative value. The value will be modified and correct after measuring motors.

Dimensions

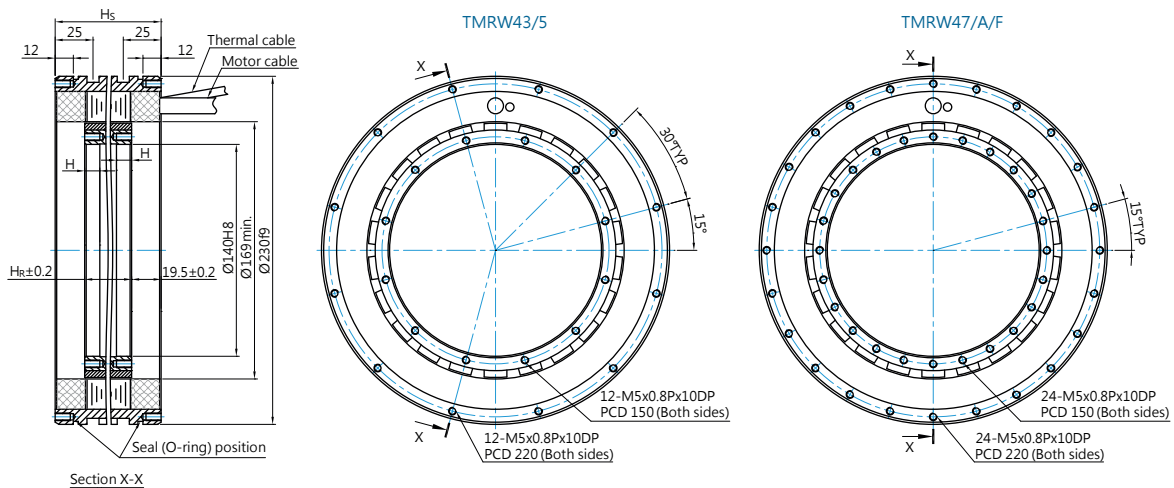

TMRW7x

Specifications

	Symbol	Unit	TMRW73	TMRW73L	TMRW75	TMRW75L	TMRW77	TMRW77L	TMRW7A	TMRW7AL	TMRW7F	TMRW7FL
Continuous torque (Free air convection)	T_c	Nm	58	58	98	98	137	137	195	195	293	293
Continuous current (Free air convection)	I_c	A_{rms}	6	12	6	12	6	12	6	12	6	12
Continuous torque (WC)	T_c	Nm	145	145	240	240	335	335	480	480	720	720
Continuous current (WC)	I_c	A_{rms}	15	30	15	30	15	30	15	30	15	30
Peak torque(for 1sec.)	T_p	Nm	275	275	456	456	640	640	910	910	1360	1360
Peak current(for 1sec.)	I_p	A_{rms}	40.5	81	40.5	81	40.5	81	40.5	81	40.5	81
Torque constant	K_t	Nm/A_{rms}	9.77	4.89	16.3	8.15	22.8	11.4	32.56	16.28	48.85	24.45
Electrical time constant	T_e	ms	5.6	5.6	5.6	5.6	5.6	5.6	5.6	5.6	5.6	5.6
Resistance (line to line at 25°C)	R_{25}	Ω	2.86	0.72	4.19	1.05	5.52	1.38	7.52	1.88	10.84	2.71
Inductance (line to line)	L	mH	16	4	23.45	5.86	30.9	7.73	42.07	10.52	60.68	15.17
Number of poles	2p		44	44	44	44	44	44	44	44	44	44
Back emf constant (line to line)	K_v	$V_{rms}/rad/s$	5.64	2.82	9.4	4.7	13.2	6.6	18.8	9.4	28.2	14.1
Motor constant (at 25°C)	K_m	N/\sqrt{W}	4.72	4.71	6.5	6.49	7.92	7.92	9.69	9.69	12.11	12.13
Thermal resistance (Free air convection)	R_{th}	$^{\circ}C/W$	0.62	0.61	0.42	0.42	0.32	0.32	0.23	0.23	0.16	0.16
Thermal resistance (WC)	R_{th}	$^{\circ}C/W$	0.098	0.098	0.067	0.067	0.051	0.051	0.037	0.037	0.026	0.026
Thermal sensor			PTC SNM100+SNM120+KTY84									
Max. DC BUS	V_{DC}		600									
Inertia of rotor	J	kgm^2	0.023	0.023	0.039	0.039	0.059	0.059	0.079	0.079	0.11	0.11
Max. speed at conti. Torque (AC)		rpm	560	1130	325	675	225	475	160	325	100	210
Max. speed at conti. Torque (WC)		rpm	470	980	270	580	180	400	115	275	72	170
Max. speed at max. Torque		rpm	270	580	150	340	90	230	50	150	13	85
Mass of rotor		kg	2.5	2.5	4.1	4.1	5.7	5.7	8.1	8.1	12.1	12.1
Mass of stator		kg	14.2	14.2	18.9	18.9	23.7	23.7	30.9	30.9	43.6	43.6
Height of stator	H_s	mm	80	80	100	100	120	120	150	150	200	200
Height of rotor	H_R	mm	31	31	51	51	71	71	101	101	151	151
Length	H	mm	10	10	15	15	15	15	15	15	15	15

WC: with water cooling

Except dimensions, all the specifications in the table are in $\pm 10\%$ of tolerance.

Note: The specification is estimative value. The value will be modified and correct after measuring motors.

Dimensions

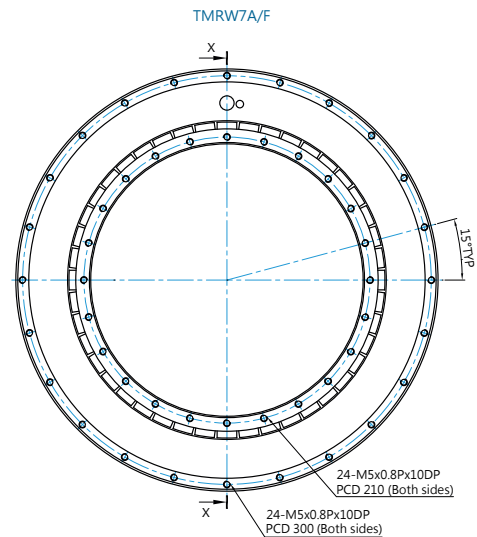
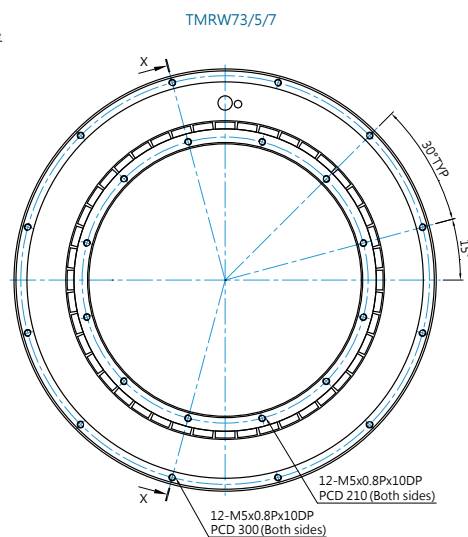
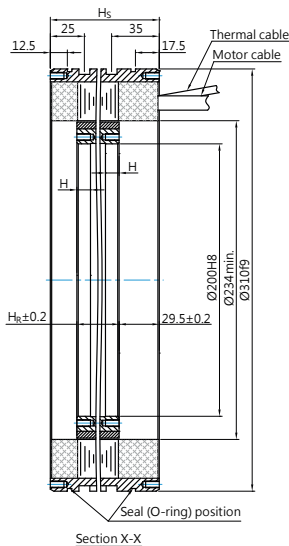

Applications

Rotary table/Indexing table



*The specifications in this catalog are subject to change without notification.

HIWIN[®]

Motion Control and System Technology



HIWIN MIKROSYSTEM CORP.
No.6, Jingke Central Rd.,
Taichung Precision Machinery Park,
Taichung 40852, Taiwan
Tel : +886-4-23550110
Fax: +886-4-23550123
www.hiwinmikro.com.tw
business@hiwinmikro.com.tw

HIWIN GmbH
OFFENBURG, GERMANY
www.hiwin.de
www.hiwin.eu
info@hiwin.de

HIWIN JAPAN
KOBE · TOKYO · NAGOYA · KUMAMOTO,
JAPAN
www.hiwin.co.jp
info@hiwin.co.jp

HIWIN USA
CHICAGO · SILICON VALLEY, U.S.A.
www.hiwin.com
info@hiwin.com

HIWIN s.r.o.
BRNO, CZECH REPUBLIC
www.hiwin.cz
info@hiwin.cz

HIWIN SCHWEIZ
JONA, SWITZERLAND
www.hiwin.ch
info@hiwin.ch

HIWIN FRANCE
L'AIGLE Cedex, FRANCE
www.hiwin.fr
info@hiwin.fr

HIWIN Srl
Rho (MI), ITALY
www.hiwin.it
info@hiwin.it

HIWIN SINGAPORE
SINGAPORE
www.hiwin.sg
info@hiwin.sg

Mega-Fabs Motion System, Ltd.
YOKNEAM, ISRAEL
www.mega-fabs.com
info@mega-fabs.com